



# WINSTON / ROYAL GUARD CORPORATION

## *Type 120 Centrifugal Separator*



The Winston/Royal Guard centrifugal separator with the Directional Blade™ internal is an efficient way to remove condensate, oil, water, pipe scale, rust, and dust from a gas, air, or steam process to protect gas and air compressors, steam turbines, and other equipment. The design of our internal allows for a more compact vessel, making it an excellent choice for applications where space is limited. Refineries, Petrochemical plants, and gas plants benefit from the separator's compact design.

**How it works:** Vapor in the form of gas, steam, or air along with entrained liquids and solid contaminants enters the separator and passes through the Directional Blade™ internal. With velocity control, the Directional Blade™ with fixed, non-moving blades imparts a spin to the flow, directing entrained liquids and solids to the vessel wall through the process of centrifugal force. Liquids coalesce on the interior surface of the vessel and, with the solid contaminants, continue to move along the wall with the spinning flow toward the end of the vessel and the drain. Clean, moisture free vapor exits the separator outlet.

### **Benefits:**

- Removes 99.9% of 8-10 micron and larger size liquid and solid particles.
- Excellent for separation of paraffin. Hand holes can be added for steam cleaning.
- Low pressure drop.

### **ASME Code Certified:**

Winston/Royal Guard Corp. is an ASME Section VIII, Division 1 Code certified manufacturing facility with National Board certification. Capabilities include all types of non-destructive testing with a rigidly controlled Quality Control system.



# Type 120 Centrifugal Separator with the Directional Blade™ for Gas • Steam • Air

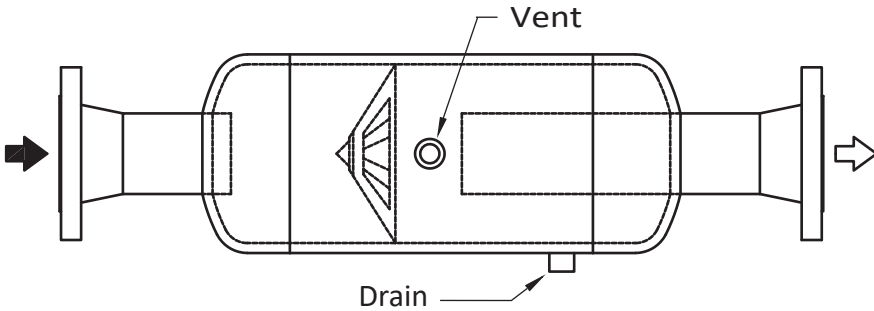

Type 120H Horizontal Flow

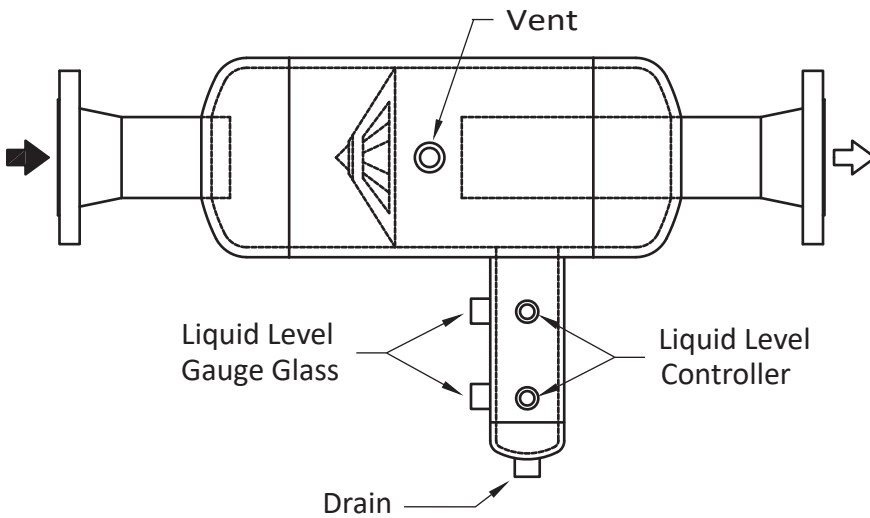

Type 120H-B Horizontal Flow  
With Boot for Gas Service

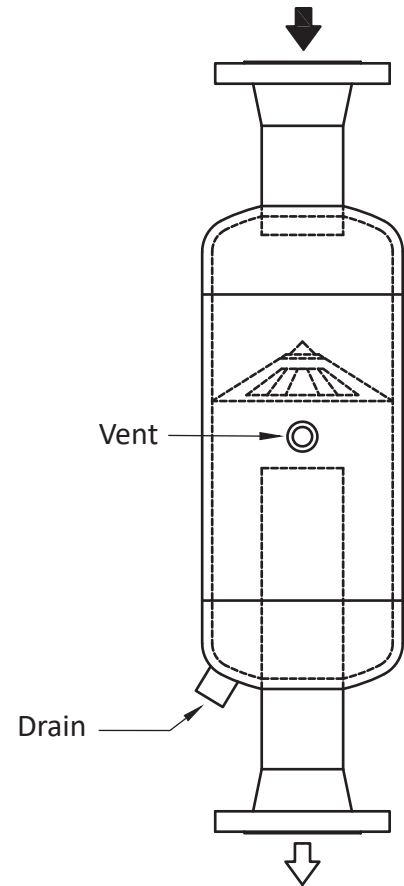

Type 120D Downflow

Specifications are subject to change without notice. 8-26-2019 (supersedes 8-24-2017)

## WINSTON / ROYAL GUARD CORPORATION

P. O. Box 1145 • White Oak, Texas 75693 USA

Phone (800) 527-8465 • (903) 757-7341 • Fax (903) 759-6986

Winston-RoyalGuard.com • e-mail: sales@winston-royalguard.com

Copyright © 2017 Winston/Royal Guard Corporation. All rights reserved