



WINSTON / ROYAL GUARD CORPORATION

Type 55 & 56 Fabricated Simplex Strainers

The Winston/Royal Guard **Type 55** and **56** fabricated heavy duty simplex strainers protect pumps, compressors, valves, and downstream equipment by removing sand, dirt, pipe scale, grit, welding beads and other solids from liquids and gases.

Applications include natural gas, process gas, chemicals, hydrocarbons, process liquids, process water, steam, and others for the refining, chemical, petrochemical, power, pulp and paper, natural gas, and other industries.

Standard material for the body and flanges is carbon steel with 304 stainless steel basket (carbon steel optional). Available materials for body and flanges are 300 series stainless steels (all or wetted parts), alloy 20, monel 400, nickel 200, hastelloy B and C276, inconel, incoloy, and chrome moly. Except for chrome moly, the basket can be manufactured in any of these materials.

Shown above is the Type 55 with support legs with grounding tab, flanged top with lifting davit, and lifting eyes (lifting provisions can be located per customer preference).

The Internal perforated basket is manufactured from heavy gauge material and seam welded for maximum protection. The oversized body and basket is designed for a lower pressure drop.

A complete selection of perforated metal and wire cloth is available for various openings and retention requirements. Typical basket openings are 80 mesh (0.0070" opening) for gas service, 40 mesh (0.0150" opening) for steam, and perforated with 1/8" diameter holes on 3/16" centers for process liquids. Baskets with most wire mesh sizes will have perforated support.

The Top cover is available as a bolted blind flange with lifting handle or davit, or a quick-opening closure for easier and faster access for basket cleaning. Inlet/outlet styles include flanged or butt weld.

Options include ASME Code stamp, open bottom basket for blowdown, support legs or skirt, lifting eye(s), differential pressure connections, vent, steam jacket, and other customer requirements.

ASME Code Certified: Winston/Royal Guard is an ASME Section VIII, Division 1 Code certified manufacturing facility with National Board certification. Capabilities include all types of non-destructive testing with a rigidly controlled Quality Control system.





WINSTON / ROYAL GUARD CORPORATION

Type 55 & 56 Fabricated Simplex Strainers

Type 55-Q

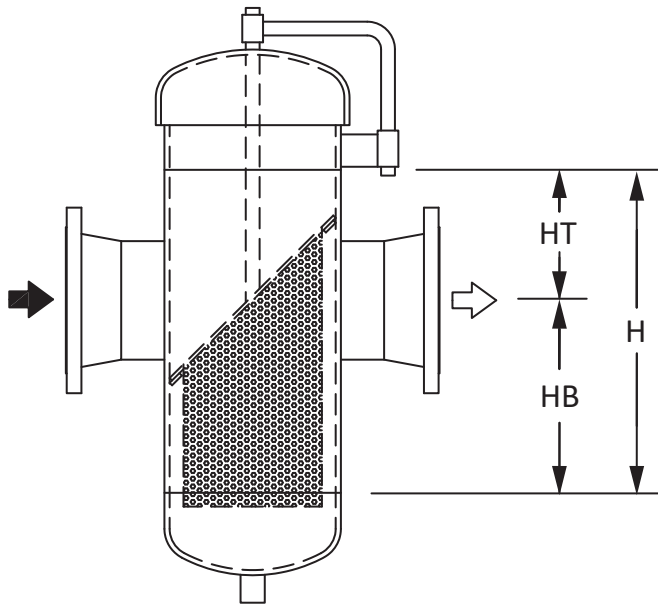

Type 55-F

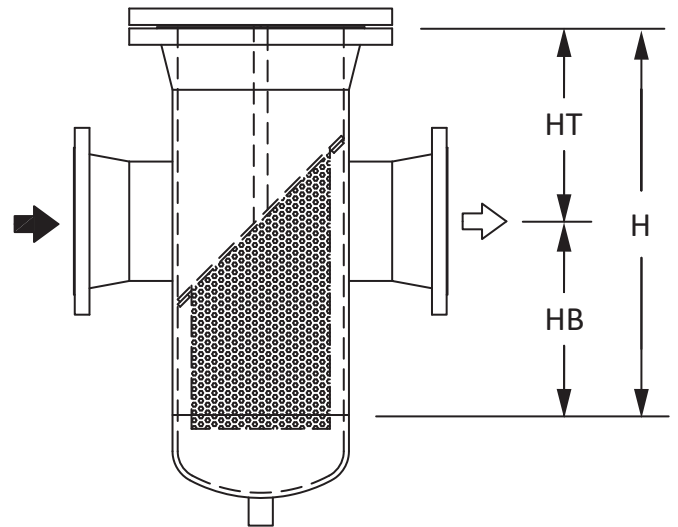

Dimensions are for 150# and 300# ANSI ratings:

SIZE NOZZLE (NOMINAL)	O.D.	H	HB	A	FLANGED COVER HT	QUICK-OPENING HT
1-1/2	3-1/2	16	8	16	8	5
2	4-1/2	16	8	16	8	6
3	6-5/8	18	8	22	10	8
4	8-5/8	22	10	24	12	11
6	10-3/4	28	14	26	14	14
8	12-3/4	28	14	32	14	17
10	14	34	18	34	16	19
12	16	38	21	36	17	22
14	18	47	29	40	18	24
16	20	51	31	42	20	26
18	24	55	33	48	22	28
20	24	58	36	48	22	30
24	30	66	41	54	25	36

Type 55-F Basket



Dimensions are in inches. Tolerance is plus or minus 1/8". Strainer baskets have a 3:1 open area minimum with a standard perforated basket of 1/8" diameter holes on 3/16" centers. Perforated material is 40% open area.

Larger sizes and higher pressure ratings are available. Please contact factory.



WINSTON / ROYAL GUARD CORPORATION

Type 55 & 56 Fabricated Simplex Strainers

Threaded High Pressure
Quick-Opening Closure

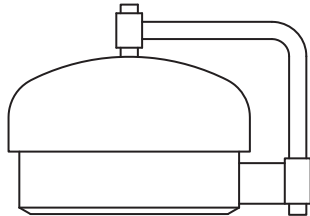

Hinged Swing-Bolt
Quick-Opening Closure
For Lower Pressure Ranges

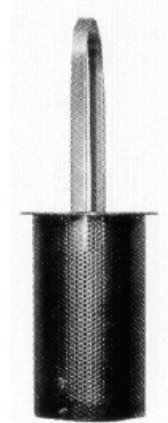
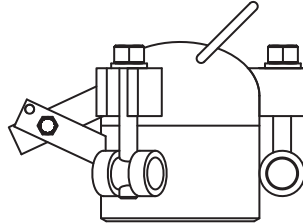

Type 56-F basket

Type 56-Q with
Flat Top basket

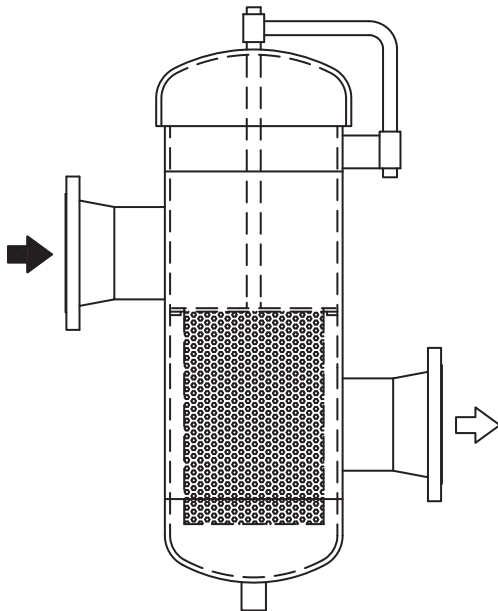

Type 56-F with
Flat Top Basket

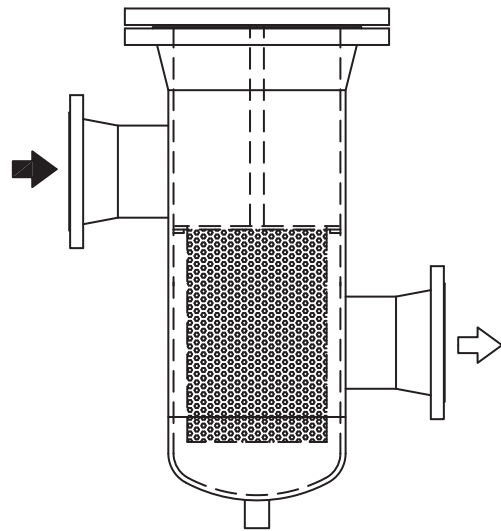

Type 58FB-Q
Horizontal
Strainer



WINSTON / ROYAL GUARD CORPORATION

TYPE 55 FABRICATED SIMPLEX STRAINER PRESSURE DROP

CLEAN PERFORATED BASKET WITH 1/8" DIAMETER HOLES

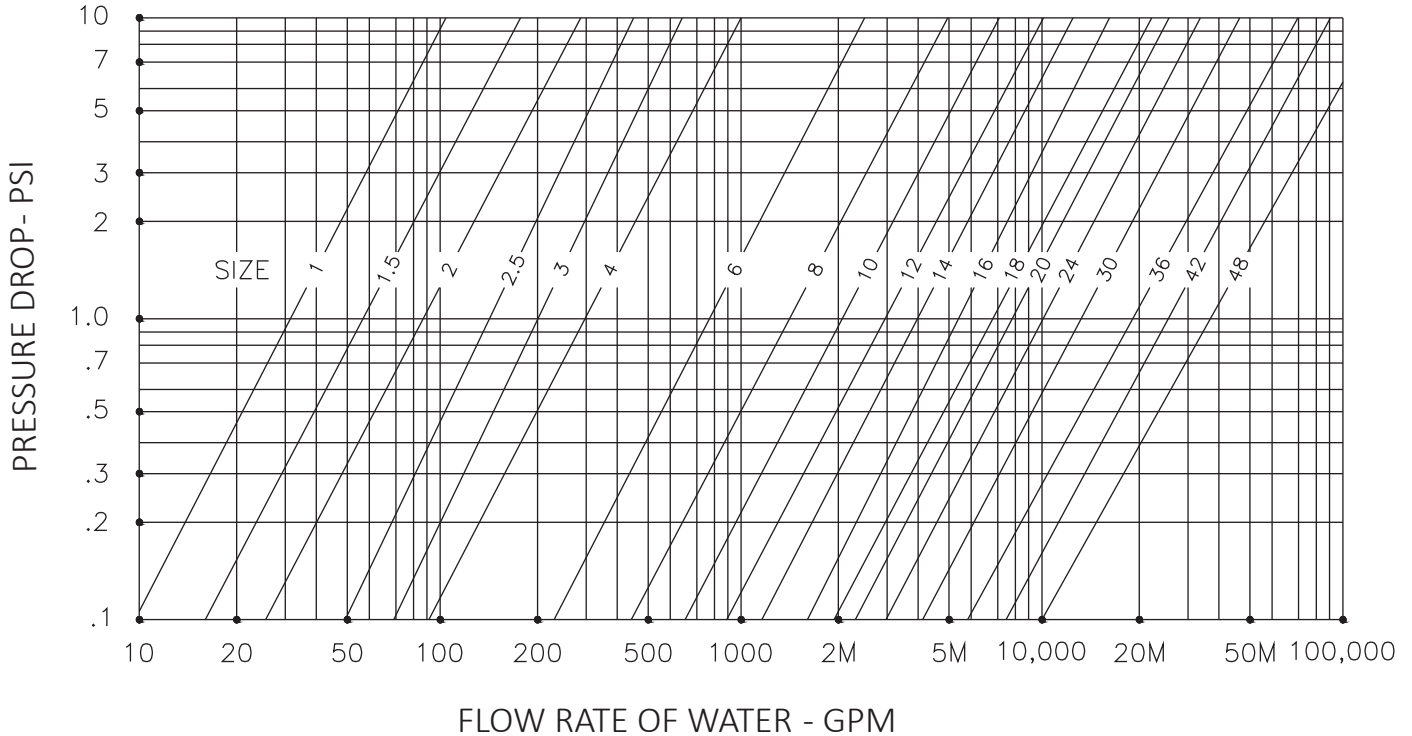

CORRECTION FACTOR

FOR LIQUIDS MORE VISCOUS THAN WATER OR WHERE A WIRE LINER IS ADDED, MULTIPLY PRESSURE DROP IN CHARTS BY:

VISCOSITY (SSU)	PERFORATED 1/8" DIA. HOLES	PERFORATED WITH WIRE CLOTH		
		40 MESH	60 MESH	80 MESH
30	1.00	1.32	1.53	1.62
270	1.30	1.61	1.83	2.00
385	1.44	1.76	2.00	2.20
500	1.58	1.92	2.13	2.41
1000	1.66	2.22	2.41	2.63
2000	1.86	2.41	2.72	2.91

FOR WATER USE 30 SSU

Specifications are subject to change without notice. 2-6-2019 (supersedes 12-20-2017)

WINSTON / ROYAL GUARD CORPORATION

P. O. Box 1145 • White Oak, Texas 75693 USA

Phone (800) 527-8465 • (903) 757-7341 • Fax (903) 759-6986

Winston-RoyalGuard.com • e-mail: sales@winston-royalguard.com

Copyright © 2017 Winston/Royal Guard Corporation. All rights reserved